

Application guidelines

Danfoss scroll for refrigeration **LLZ013 to 034 with NI/VI/LI** Low temperature

50-60 Hz - R404A, R507



GENERAL INFORMATION.....	4	Manage superheat	28
		Requirement	28
		Evaluate the risk.....	28
		Test, criteria and solutions.....	28
PRODUCT INFORMATION	5	Manage off cycle migration.....	29
Features.....	5	Requirement	29
Overview	5	Evaluate the risk.....	29
Compressor model designation	6	Test, criteria and solutions.....	29
Nomenclature	6	Control logic	30
Technical specifications.....	7	Safety control logic requirements.....	30
50-60 Hz data	7	Cycle rate limit requirements	30
Dimensions	10	Oil management logic recommendations ...	30
Single compressors LLZ013-015-018	10	Defrost logic recommendations	30
Single compressors LLZ024.....	11	Pump-down logic recommendations.....	31
Single compressors LLZ034	12	Provide power supply and electrical	
Electrical data, connections and wiring14		protection	32
Motor voltage.....	14	Wiring information	32
Wiring connections	14	INTEGRATION INTO SYSTEMS.....	33
IP rating.....	15	Reduce moisture in the system.....	33
Three phase electrical characteristics	15	Requirements	33
Motor protection.....	16	Solutions	33
Approval and certificates	17	Assembly line procedure.....	34
Pressure equipment directive	17	Compressor storage.....	34
Low voltage directive.....	17	Compressor holding charge	34
Machines directive	17	Handling	34
Internal free volume.....	17	Piping assembly.....	35
SYSTEM DESIGN.....	18	System pressure test and leak detection	35
Design piping	18	Vacuum evacuation and moisture removal	36
General requirements	18	Refrigerant charging.....	36
Design compressor mounting	19	Dielectric strength and insulation resistance	
General requirements	19	tests	36
Single compressor requirements.....	19	Commissioning.....	37
Manage sound and vibration.....	20	Preliminary check.....	37
Compressor sound radiation	20	Initial start-up.....	37
Mechanical vibrations	21	System monitoring.....	37
Gas pulsation	21	Dismantle and disposal	38
Manage operating envelope.....	22	ORDERING INFORMATION	39
Requirement	22	Packaging	39
Evaluate the risk.....	24	Ordering codes	40
Theory of Injection cycle	25	Accessories.....	41
Theory of Vapor injection cycle.....	25		
Theory of liquid injection cycle	25		
TREV installation.....	26		

General Information

GENERAL INFORMATION

PRODUCT INFORMATION

SYSTEM DESIGN

INTEGRATION INTO SYSTEM

ORDERING INFORMATION

Danfoss scroll compressors are designed and manufactured according to the state of the art and to valid European and US regulations. Particular emphasis has been placed on safety and reliability. Related instructions are highlighted with the following icons:

 This icon indicates instructions to avoid reliability risk.

 This icon indicates instructions to avoid safety risk.

You are strongly advised to follow these instructions. For any deviation from the guidelines, please contact Danfoss Technical Support.

In any case, Danfoss accepts no liability as a result of the improper integration of the compressor into the unit by the system manufacturer.

Overview

Danfoss scroll compressor for refrigeration, LLZ, with its unique scroll design and manufacturing process flexibility, offers a highly efficient solution for demanding refrigeration applications.

This new family of refrigeration scroll compressors includes 5 sizes of low temperature scroll compressors designed for commercial refrigeration applications. These compressors are engineered for refrigeration and offer cooling capacity from 5 to 12 kW (4 to 10 HP) at common voltages and frequencies as well as any of the common refrigerants (R404A / R507).

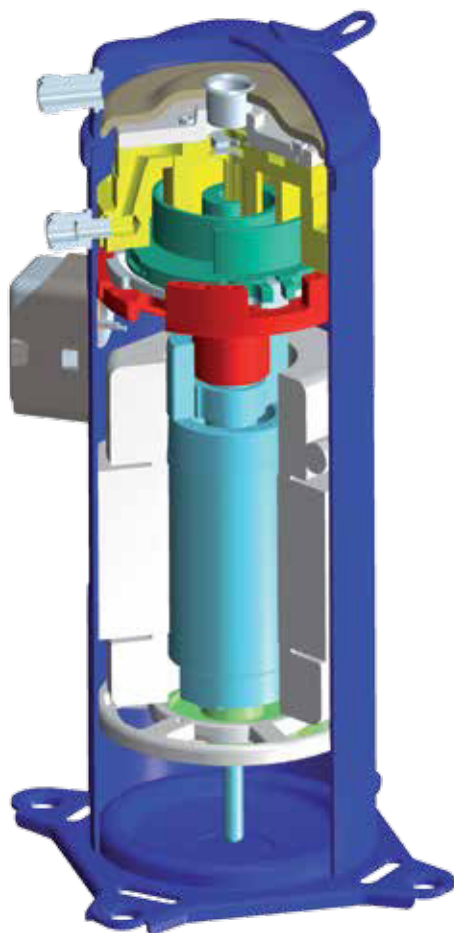

Economized compressor: In the LLZ range of refrigeration scrolls, the compressors can work with the economizer line activated, named as economized compressor; or with the economizer line disabled, named as standard compressor. The economized compressor has been developed to provide improved performance and an enlarged operating envelope in refrigeration applications. The economized compressor system presents benefits over standard refrigeration compressor systems of equivalent horse power due to the following:

- Capacity improvement: The capacity is improved without increasing compressor displacement, as it is increased by further increasing system sub cooling with a heat exchanger acting as an economizer (connected to the compressor economizer line). Furthermore a smaller economized compressor can be used to achieve the same capacity as a larger standard compressor, leading to cost advantages.
- Efficiency improvement: With a suitable sized heat exchanger, the efficiency improves due to the fact that the gain in capacity is greater than the increase in power that the compressor consumes.
- Enlarged operating envelope: The injection of vapour through the economizer line will reduce the discharge temperature and therefore enlarge the operating envelope based on the same suction status.

Standard compressor with liquid injection: The standard compressor can also connect with a liquid valve to reduce the discharge temperature and enlarge the envelope.

- Enlarged operating envelope: The liquid injection of refrigerant into the compressor will flash and absorb heat from the compressed gas and scroll set leading to cooling of the discharge gas, thus keeping the discharge gas temperature within safe limits. The enlarged operating envelope is therefore based on the same suction status.

GENERAL INFORMATION
PRODUCT INFORMATION
SYSTEM DESIGN
INTEGRATION INTO SYSTEM
ORDERING INFORMATION

Compressor model designation

Danfoss scroll compressor LLZ for R404A, R507 is available as single compressor and can be assembled in manifolding combinations.

The example below presents the compressor nomenclature which equals the technical reference as shown on the compressor nameplate. Code numbers for ordering are listed section "Ordering information and packaging".

Nomenclature

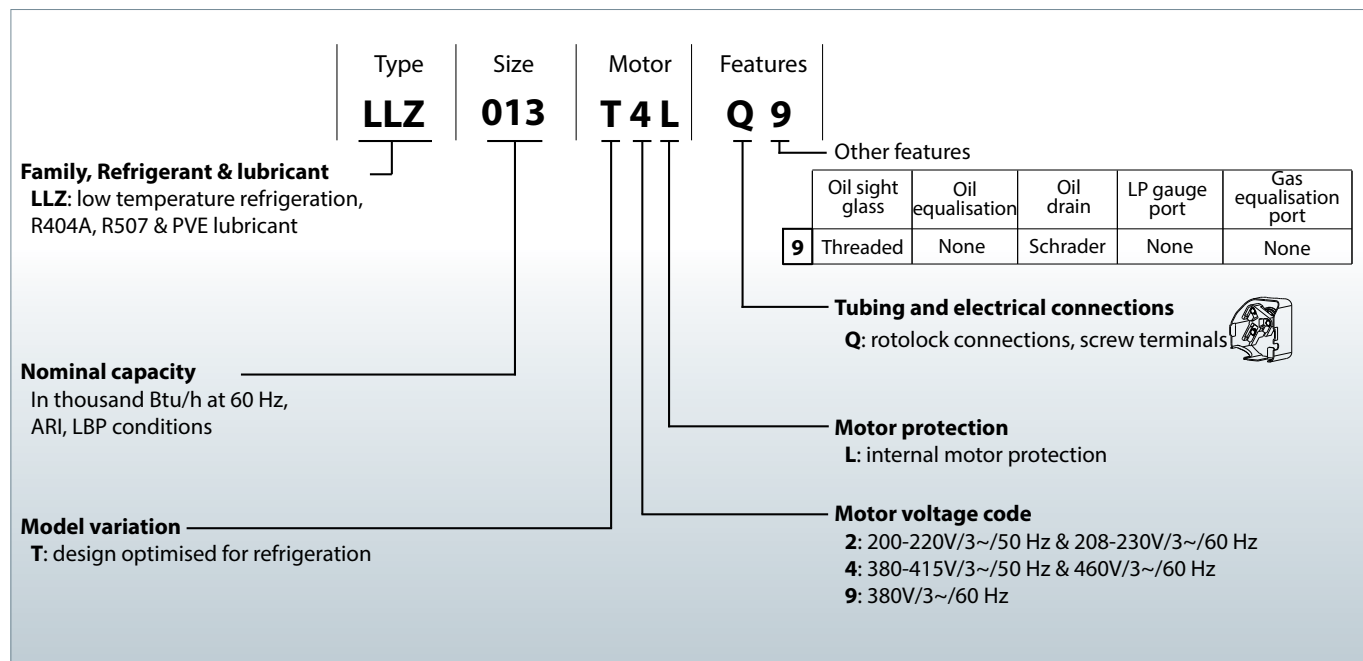

Technical specifications

50-60 Hz data

Model with activated economizer line only

Models Refrigerant	Nominal tons 60 Hz	Nominal cooling capacity		Power input	COP	E.E.R.	Swept volume	Displace- ment ①	Oil charge	Net weight ②	
		TR	W	Btu/h	W	W/W	Btu/h/W	cm ³ /rev	m ³ /h	dm ³	kg
50 Hz R404A/507*	LLZ013	4	4044	13802	3011	1.34	4.57	67.4	11.7	1.62	42
	LLZ015	5	4840	16519	3511	1.38	4.71	83.5	14.5	1.62	42
	LLZ018	6	5766	19679	4041	1.43	4.88	97.6	17	1.62	43
	LLZ024	8	7242	24717	4994	1.45	4.95	120.2	20.9	2.51	46
	LLZ034	10	9907	33812	6597	1.50	5.12	168.7	29.4	2.51	51
60 Hz R404A/507*	LLZ013	4	4863	16597	3482	1.40	4.78	67.4	14.2	1.62	42
	LLZ015	5	5778	19720	4158	1.39	4.74	83.5	17.5	1.62	42
	LLZ018	6	6905	23567	4739	1.46	4.98	97.6	20.5	1.62	43
	LLZ024	8	8555	29198	5784	1.48	5.05	120.2	25.3	2.51	46
	LLZ034	10	12041	41096	7807	1.54	5.26	168.7	35.4	2.51	51

① Displacement at nominal speed: 2900 rpm at 50 Hz, 3500 rpm at 60 Hz

② Net weight with oil charge

TR: Ton of Refrigeration,
EER: Energy Efficiency Ratio
COP: Coefficient Of Performance

Standard rating conditions: EN12900
Refrigerant: R404A*

Evaporating temperature: -35 °C
Condensing temperature: 40 °C
Economizer SH: 5 K

Superheat: 10 K
Subcooling: 5 K
Economizer ΔT: 5 K

All of the compressor performance test after run-in 72h

*R507 performance data are nearly identical to R404A performance data

Subject to modification without prior notification.

Data given for motor code 4 compressor, for full data details and capacity tables refer to Online Datasheet Generator: www.danfoss.com/odsg

Model without activated economizer line, without liquid injection

Models Refrigerant	Nominal tons 60 Hz	Nominal cooling capacity		Power input	COP	E.E.R.	Swept volume	Displace- ment ①	Oil charge	Net weight ②	
		TR	W	Btu/h	W	W/W	Btu/h/W	cm ³ /rev	m ³ /h	dm ³	kg
50 Hz R404A/R507*	LLZ013	4	2417	8249	2366	1.02	3.48	67.4	11.7	1.62	42
	LLZ015	5	2937	10024	2776	1.06	3.62	83.5	14.5	1.62	42
	LLZ018	6	3453	11785	3150	1.10	3.75	97.6	17	1.62	43
	LLZ024	8	4411	15055	3957	1.11	3.79	120.2	20.9	2.51	46
	LLZ034	10	6051	20652	5458	1.11	3.79	168.7	29.4	2.51	51
60 Hz R404A/R507*	LLZ013	4	2896	9884	2774	1.04	3.55	67.4	14.2	1.62	42
	LLZ015	5	3552	12123	3307	1.07	3.65	83.5	17.5	1.62	42
	LLZ018	6	4228	14430	3799	1.11	3.79	97.6	20.5	1.62	43
	LLZ024	8	5278	18014	4611	1.14	3.89	120.2	25.3	2.51	46
	LLZ034	10	7404	25270	6157	1.20	4.10	168.7	35.4	2.51	51

① Displacement at nominal speed: 2900 rpm at 50 Hz, 3500 rpm at 60 Hz

② Net weight with oil charge

TR: Ton of Refrigeration,
EER: Energy Efficiency Ratio
COP: Coefficient Of Performance

Standard rating conditions: EN12900
Refrigerant: R404A*

Evaporating temperature: -35 °C
Condensing temperature: 40 °C

Superheat: 10 K
Subcooling: 0 K

All of the compressor performance test after run-in 72h

*R507 performance data are nearly identical to R404A performance data

Subject to modification without prior notification.

Data given for motor code 4 compressor, for full data details and capacity tables refer to Online Datasheet Generator: www.danfoss.com/odsg

Technical specifications

50-60 Hz data

Model with activated economizer line only

Models Refrigerant	Nominal tons 60 Hz	Nominal cooling capacity		Power input	COP	E.E.R.	Swept volume	Displace- ment ①	Oil charge	Net weight ②	
		TR	W	Btu/h	W	W/W	Btu/h/W	cm ³ /rev	m ³ /h	dm ³	kg
50 Hz R404A	LLZ013	4	4819	16447	3087	1.56	5.32	67.4	11.7	1.62	42
	LLZ015	5	5713	19498	3595	1.59	5.43	83.5	14.5	1.62	42
	LLZ018	6	6806	23229	4137	1.64	5.60	97.6	17	1.62	43
	LLZ024	8	8548	29174	5113	1.67	5.70	120.2	20.9	2.51	46
	LLZ034	10	11624	39672	6805	1.71	5.84	168.7	29.4	2.51	51
60 Hz R404A	LLZ013	4	5776	19713	3573	1.62	5.53	67.4	14.2	1.62	42
	LLZ015	5	6821	23280	4266	1.60	5.46	83.5	17.5	1.62	42
	LLZ018	6	8152	27823	4861	1.68	5.73	97.6	20.5	1.62	43
	LLZ024	8	10100	34471	5934	1.70	5.80	120.2	25.3	2.51	46
	LLZ034	10	14028	47877	8055	1.74	5.94	168.7	35.4	2.51	51

① Displacement at nominal speed: 2900 rpm at 50 Hz, 3500 rpm at 60 Hz

② Net weight with oil charge

TR: Ton of Refrigeration,
EER: Energy Efficiency Ratio

Standard rating conditions: ARI
Refrigerant: R404A*

Evaporating temperature: -31.7 °C
Condensing temperature: 40.6 °C

Superheat: 50 K
Subcooling: 5 K
Economizer ΔT: 5K

COP: Coefficient Of Performance

Economizer SH: 5 K

All of the compressor performance test after run-in 72h

*R507 performance data are nearly identical to R404A performance data

Subject to modification without prior notification.

Data given for motor code 4 compressor, for full data details and capacity tables refer to Online Datasheet Generator: www.danfoss.com/odsg

Model without activated economizer line, without liquid injection

Models Refrigerant	Nominal tons 60 Hz	Nominal cooling capacity		Power input	COP	E.E.R.	Swept volume	Displace- ment ①	Oil charge	Net weight ②	
		TR	W	Btu/h	W	W/W	Btu/h/W	cm ³ /rev	m ³ /h	dm ³	kg
50 Hz R404A	LLZ013	4	3213	10966	2507	1.28	4.37	67.4	11.7	1.62	42
	LLZ015	5	3898	13304	2949	1.32	4.51	83.5	14.5	1.62	42
	LLZ018	6	4583	15642	3346	1.37	4.68	97.6	17	1.62	43
	LLZ024	8	5854	19980	4204	1.39	4.74	120.2	20.9	2.51	46
	LLZ034	10	7991	27273	5772	1.38	4.71	168.7	29.4	2.51	51
60 Hz R404A	LLZ013	4	3857	13164	2938	1.31	4.47	67.4	14.2	1.62	42
	LLZ015	5	4718	16102	3507	1.35	4.61	83.5	17.5	1.62	42
	LLZ018	6	5616	19167	4028	1.39	4.74	97.6	20.5	1.62	43
	LLZ024	8	7011	23928	4889	1.43	4.88	120.2	25.3	2.51	46
	LLZ034	10	9791	33416	6616	1.48	5.05	168.7	35.4	2.51	51

① Displacement at nominal speed: 2900 rpm at 50 Hz, 3500 rpm at 60 Hz

② Net weight with oil charge

TR: Ton of Refrigeration,
EER: Energy Efficiency Ratio

Standard rating conditions: ARI
Refrigerant: R404A*

Evaporating temperature: -31.7 °C
Condensing temperature: 40.6 °C

Superheat: 50 K
Subcooling: 0 K

COP: Coefficient Of Performance

All of the compressor performance test after run-in 72h

*R507 performance data are nearly identical to R404A performance data

Subject to modification without prior notification.

Data given for motor code 4 compressor, for full data details and capacity tables refer to Online Datasheet Generator: www.danfoss.com/odsg

Technical specifications

50-60 Hz data

Model with liquid injection only

Models Refrigerant	Nominal tons 60 Hz	Nominal cooling capacity		Power input	COP	E.E.R.	Swept volume	Displacement ①	Oil charge	Net weight ②	
		TR	W								Btu/h
50 Hz R404A/507*	LLZ013	4	2255	7694	2285	0.99	3.38	67.4	11.7	1.62	42
	LLZ015	5	2814	9601	2811	1.00	3.41	83.5	14.5	1.62	42
	LLZ018	6	3307	11283	3247	1.02	3.48	97.6	17	1.62	43
	LLZ024	8	4086	13941	4016	1.02	3.47	120.2	20.9	2.51	46
	LLZ034	10	5807	19813	5619	1.03	3.53	168.7	29.4	2.51	51
60 Hz R404A/507*	LLZ013	4	2754	9397	2750	1.00	3.41	67.4	14.2	1.62	42
	LLZ015	5	3407	11625	3355	1.02	3.46	83.5	17.5	1.62	42
	LLZ018	6	4031	13754	3809	1.06	3.61	97.6	20.5	1.62	43
	LLZ024	8	5024	17142	4703	1.07	3.64	120.2	25.3	2.51	46
	LLZ034	10	7154	24409	6383	1.12	3.82	168.7	35.4	2.51	51

① Displacement at nominal speed: 2900 rpm at 50 Hz, 3500 rpm at 60 Hz

② Net weight with oil charge

TR: Ton of Refrigeration,
EER: Energy Efficiency Ratio
COP: Coefficient Of Performance

Standard rating conditions: EN12900
Refrigerant: R404A*

Evaporating temperature: -35 °C
Condensing temperature: 40 °C

Superheat: 10 K
Subcooling: 0 K

All of the compressor performance test after run-in 72h

*R507 performance data are nearly identical to R404A performance data

Subject to modification without prior notification.

Data given for motor code 4 compressor, for full data details and capacity tables refer to Online Datasheet Generator: www.danfoss.com/odsg

All of these performance data base on using the injection valve: Sporlan Y1037-1/2-230-3/8ODFX3/8ODF

Model with liquid injection only

Models Refrigerant	Nominal tons 60 Hz	Nominal cooling capacity		Power input	COP	E.E.R.	Swept volume	Displacement ①	Oil charge	Net weight ②	
		TR	W								Btu/h
50 Hz R404A/507*	LLZ013	4	3027	10341	2403	1.26	4.30	67.4	11.7	1.62	42
	LLZ015	5	3777	12887	2957	1.28	4.36	83.5	14.5	1.62	42
	LLZ018	6	4439	15146	3415	1.30	4.44	97.6	17	1.62	43
	LLZ024	8	5450	18595	4225	1.29	4.40	120.2	20.9	2.51	46
	LLZ034	10	7746	26429	5912	1.31	4.47	168.7	29.4	2.51	51
60 Hz R404A/507*	LLZ013	4	3694	12604	2896	1.28	4.35	67.4	14.2	1.62	42
	LLZ015	5	4569	16688	3533	1.29	4.41	83.5	17.5	1.62	42
	LLZ018	6	5406	18445	4011	1.35	4.60	97.6	20.5	1.62	43
	LLZ024	8	6691	22830	4956	1.35	4.60	120.2	25.3	2.51	46
	LLZ034	10	9528	32510	6727	1.41	4.83	168.7	35.4	2.51	51

① Displacement at nominal speed: 2900 rpm at 50 Hz, 3500 rpm at 60 Hz

② Net weight with oil charge

TR: Ton of Refrigeration,
EER: Energy Efficiency Ratio
COP: Coefficient Of Performance

Standard rating conditions: ARI
Refrigerant: R404A*

Evaporating temperature: -31.7 °C
Condensing temperature: 40.6 °C

Superheat: 50 K
Subcooling: 0 K

All of the compressor performance test after run-in 72h

*R507 performance data are nearly identical to R404A performance data

Subject to modification without prior notification.

Data given for motor code 4 compressor, for full data details and capacity tables refer to Online Datasheet Generator: www.danfoss.com/odsg

All of these performance data base on using the injection valve: Sporlan Y1037-1/2-230-3/8ODFX3/8ODF

Dimensions

Single compressors LLZ013-015-018

GENERAL INFORMATION

PRODUCT INFORMATION

SYSTEM DESIGN

INTEGRATION INTO SYSTEM

ORDERING INFORMATION

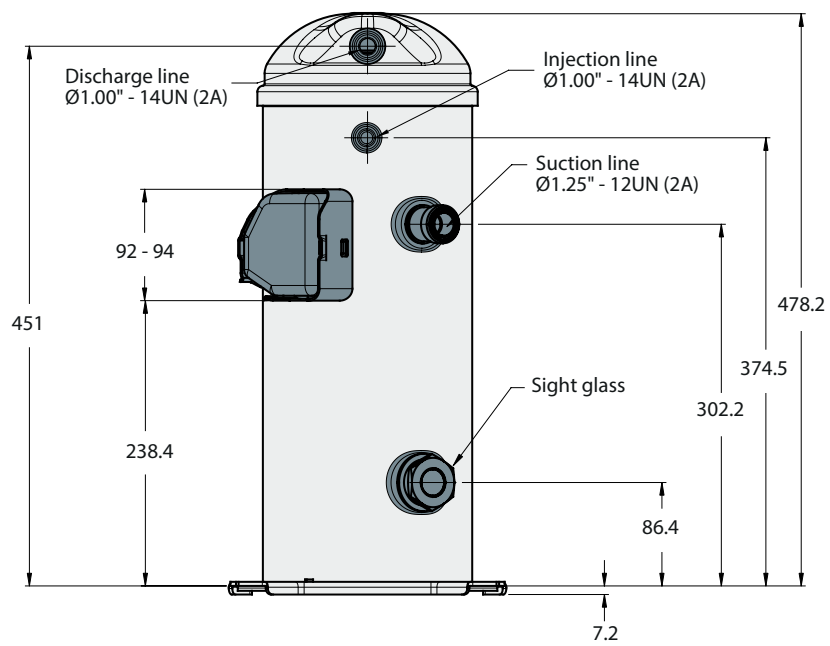
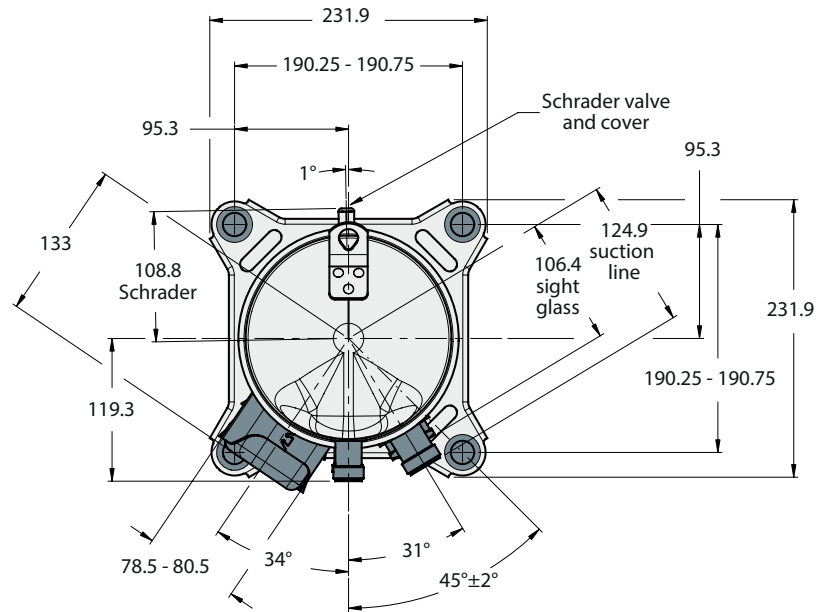

Terminal box

Mounting grommet

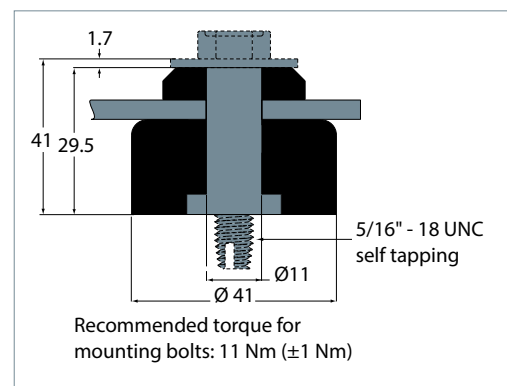
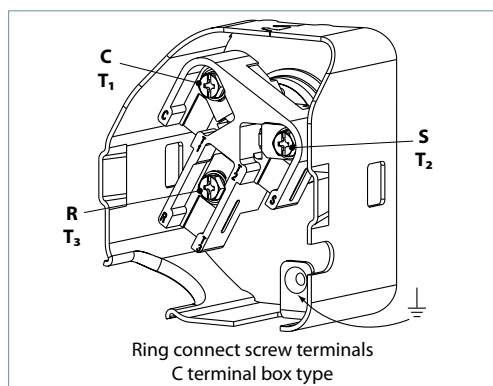

Dimensions

Single compressors LLZ024

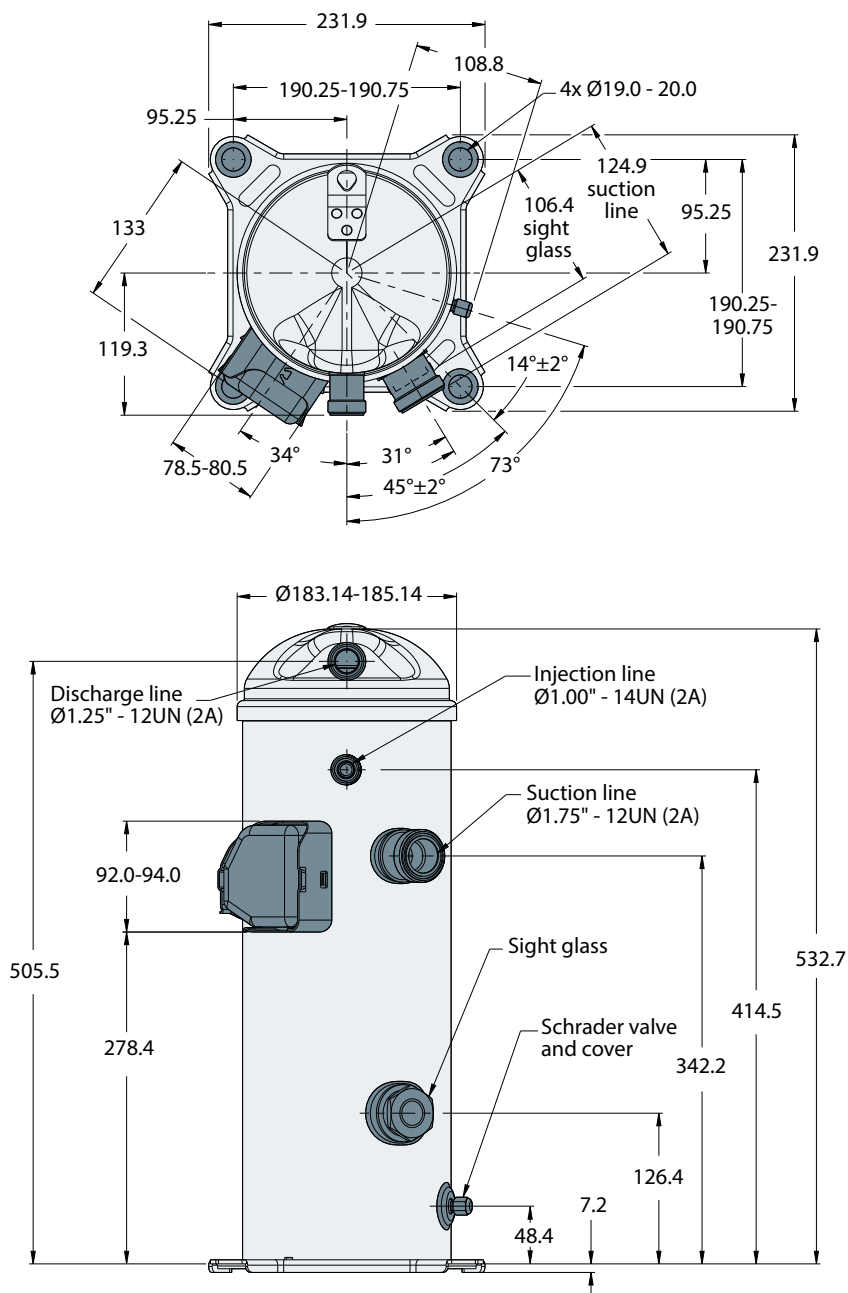

Terminal box

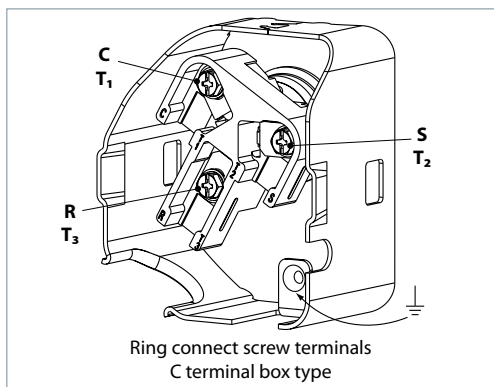

Mounting grommet

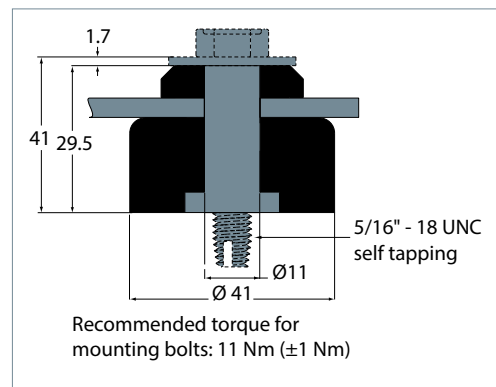

Dimensions

Single compressors LLZ034

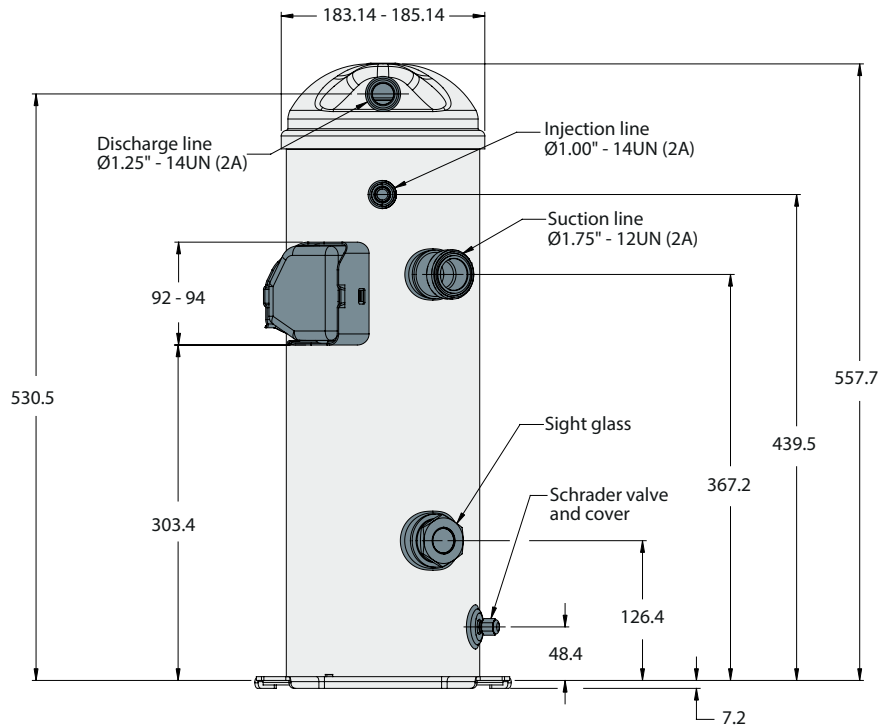
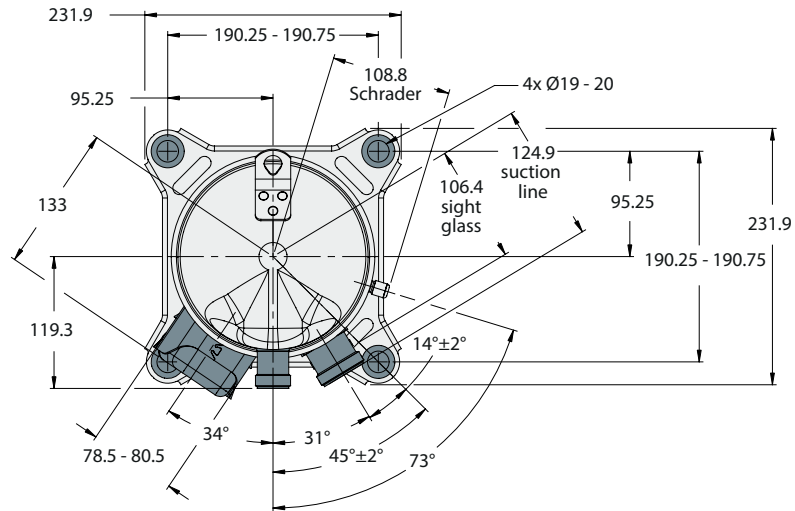

Terminal box

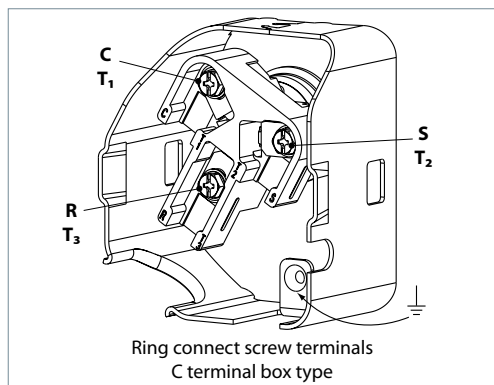

Mounting grommet

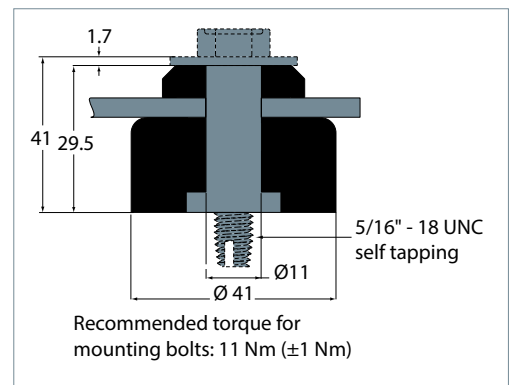

Dimensions

Oil sight glass

LLZ scroll compressors come equipped with a threaded oil sight glass with 1"1/8 - 18 UNEF connection. It can be used for a visual check of the oil amount and condition or it may be replaced by an accessory oil management device. The oil level must be visible in the sight glass during operation.

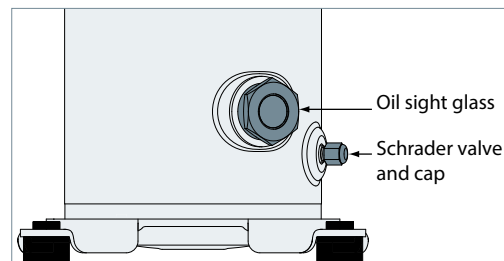

Schrader

The oil fill and drain connection and gauge port is a 1/4" male flare connector incorporating a schrader valve.

Suction and discharge connections

LLZ scroll compressors are factory delivered with rotolock connections only.

Compressor Models	Rotolock Sizes		
	Suction Fitting (in)	Discharge Fitting (in)	Injection Fitting (in)
LZL013	1"1/4	1"	1"
LLZ015	1"1/4	1"	1"
LLZ018	1"1/4	1"	1"
LLZ024	1"3/4	1"1/4	1"
LLZ034	1"3/4	1"1/4	1"

Motor voltage

Danfoss scroll compressors LLZ are available in 3 different motor voltages as listed below.

Motor voltage code		Code 2	Code 4	Code 9
50 Hz	Nominal voltage	200-220V-3 ph	380-415V - 3 ph	-
	Voltage range	180-242V*	342-457 V	
60 Hz	Nominal voltage	208-230V-3 ph	460V - 3 ph	380V -3 ph
	Voltage range	187-253V*	414-506 V	342-418V

The maximum allowable voltage imbalance is 2%. Voltage imbalance causes high amperage over one or several phases, which in turn leads to

overheating and possible motor damage. Voltage imbalance is given by the formula:

$$\% \text{ voltage imbalance} = \frac{|V_{\text{avg}} - V_{1-2}| + |V_{\text{avg}} - V_{1-3}| + |V_{\text{avg}} - V_{2-3}|}{2 \times V_{\text{avg}}} \times 100$$

V_{avg} = Mean voltage of phases 1, 2, 3.

V_{1-3} = Voltage between phases 1 and 3.

V_{1-2} = Voltage between phases 1 and 2.

V_{2-3} = Voltage between phases 2 and 3.

Wiring connections

Danfoss scroll compressors LLZ will only compress gas while rotating counter-clockwise (when viewed from the compressor top). Three-phase motors will start and run in either direction, depending on the phase angles of the supplied power. Care must be taken during installation to ensure that the compressor operates in the correct direction (see "Phase sequence and reverse rotation protection").

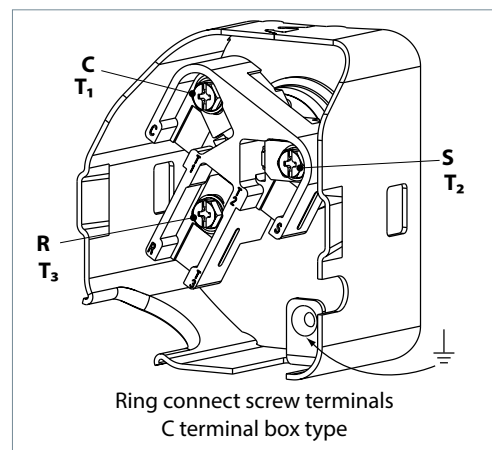

The drawings hereafter show electrical terminal labelling and should be used as a reference when wiring the compressor. For three phase applications, the terminals are labelled T1, T2, and T3. For single-phase applications the terminals are labelled C (common), S (start), and R (run).

Terminal cover mounting

The terminal cover and gasket should be installed prior to operation of the compressor. Respect the "up" marking on gasket and cover and ensure

that the two outside tabs of the cover engage the terminal box.

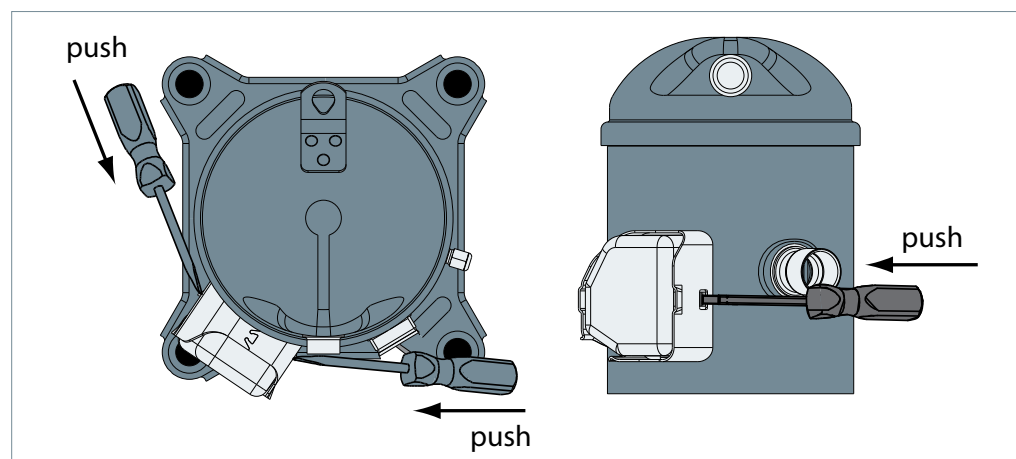
Terminal cover removal

Electrical data, connections and wiring

IP rating

The compressor terminal box IP rating according to CEI 529 is IP22 for all models. IP ratings is only valid when correctly sized cable glands of the IP rating is applied.

First numeral, level of protection against contact and foreign objects

2 - Protection against object size over 12.5 mm (fingers of similar)

Second numeral, level of protection against water

2 - Protection against dripping water when tilted up to 15°

The IP rating can be upgraded to IP54 with an accessory kit (see section "Accessories").

Three phase electrical characteristics

Compressor model		LRA	MCC	Max. operating current	Max. operating current with economizer	Winding resistance
		A	A	A	A	Ω
Motor voltage code 2 200-220 V / 3 / 50Hz 208-230 V / 3 / 60Hz	LLZ013	123.0	25.0	16.4	20.0	0.60
	LLZ015	180.0	29.0	18.9	23.0	0.50
	LLZ018	184.0	31.0	24.1	29.4	0.43
	LLZ024	190.0	40.0	28.4	34.7	0.37
	LLZ034	250.0	50.0	42.4	44.7	0.29
Motor voltage code 4 380-415/3ph/50Hz 460V/3ph/60Hz	LLZ013	62.0	12.0	8.0	9.8	2.30
	LLZ015	88.5	15.0	9.8	12.0	1.69
	LLZ018	90.0	15.0	11.8	14.4	1.61
	LLZ024	95.0	21.0	15.0	18.3	1.48
	LLZ034	150.0	26.0	19.1	22.7	0.84
Motor voltage code 9 380V/3ph/60Hz	LLZ013	81.0	14.0	9.4	11.8	1.49
	LLZ015	81.0	17.0	11.3	14.2	1.49
	LLZ018	106.0	20.0	13.7	16.5	1.13
	LLZ024	135.0	21.0	17.1	19.4	0.93
	LLZ034	155.0	29.6	22.9	25.5	0.63

Electrical data, connections and wiring

GENERAL INFORMATION		
LRA (Locked Rotor Amp)	Locked Rotor Amp value is the higher average current as measured on mechanically blocked compressor tested under nominal voltage. The LRA value can be used as rough estimation for	the starting current. However in most cases, the real starting current will be lower. A soft starter can be applied to reduce starting current.
MCC (Maximum Continuous Current)	The MCC is the current at which the motor protection trips under maximum load and low voltage conditions. This MCC value is the maximum at which the compressor can be operated in transient conditions and out of	the application envelope. Above this value, the overload or external electronic module will cut-out the compressor to protect the motor.
Max. operating Current	The max. operating current is the current when the compressors operate at maximum load conditions and 10% below nominal voltage (+15°C evaporating temperature and +68°C	condensing temperature). Max Oper. A can be used to select cables and contactors. In normal operation, the compressor current consumption is always less than the Max Oper. A. value.
Winding resistance	Winding resistance is the resistance between phases at 25°C (resistance value +/- 7%). Winding resistance is generally low and it requires adapted tools for precise measurement. Use a digital ohm-meter, a "4 wires" method and measure under stabilised ambient temperature. Winding resistance varies strongly with winding temperature. If the compressor is stabilised at a different value than 25°C, the measured resistance must be corrected using the following formula:	$R_{t_{amb}} = R_{25^{\circ}C} \frac{a + t_{amb}}{a + t_{25^{\circ}C}}$ <p> $t_{25^{\circ}C}$: reference temperature = 25°C t_{amb}: temperature during measurement (°C) $R_{25^{\circ}C}$: winding resistance at 25°C R_{amb}: winding resistance at t_{amb} Coefficient $a = 234.5$ </p>
Motor protection	<p>Danfoss scroll compressors LLZ are equipped with an internal line break protector mounted on the motor windings. The protector is an automatic reset device, containing a snap action bimetal switch.</p> <p>Internal protectors respond to over-current and overheating. They are designed to interrupt</p>	<p>Motor current under a variety of fault conditions, such as failure to start, running overload, and fan failure.</p> <p>If the internal overload protector trips out, it must cool down to about 60°C to reset. Depending on ambient temperature, this may take up to several hours.</p>
Phase sequence and reverse rotation protection	The compressor will only operate properly in a single direction. Use a phase meter to establish the phase orders and connect line phases L1, L2 and L3 to terminals T1, T2 and T3, respectively. For three-phase compressors, the motor will run equally well in both directions. Reverse rotation results in excessive noise; no pressure differential between suction and discharge; and suction line warming rather than immediate cooling. A	<p>service technician should be present at initial start-up to verify that supply power is properly phased and that compressor and auxiliaries are rotating in the correct direction.</p> <p>Phase monitors are required for LLZ compressors. The selected phase monitor should lock out the compressor from operation in reverse.</p>
ORDERING INFORMATION		

Approval and certificates

LLZ scroll compressors comply with the following approvals and certificates. Certificates are listed on the product datasheets: <http://www.danfoss.com/odsg>

CE 0062 or CE 0038 or CE0871 (European Directive)		All LLZ models
UL (Underwriters Laboratories)		All LLZ models
Other approvals / certificates		Contact Danfoss

*LVD compliant without Annex AA

Pressure equipment directive 97/23/EC

Products	LLZ013-034
Refrigerating fluids	Group 2
Category PED	I
Evaluation module	no scope

Low voltage directive 2006/95/EC

Products	LLZ013-034
Declaration of conformity ref. Low voltage Directive 2006/95/EC	Contact Danfoss

Machines directive 2006/42/EC

Products	LLZ013-034
Manufacturer's declaration of incorporation ref. Machines Directive 2006/42/EC	Contact Danfoss

Internal free volume

Products	Internal free volume at LP side without oil (litre)
LLZ013-015-018	4.74
LLZ024-034	5.95

GENERAL INFORMATION

PRODUCT INFORMATION

SYSTEM DESIGN

INTEGRATION INTO SYSTEM

ORDERING INFORMATION

General requirements

Proper piping practices should be employed to:

1. Ensure adequate oil return, even under minimum load conditions (refrigerant speed, piping slopes...). For validation tests see section "Manage oil in the circuit".

2. Avoid condensed liquid refrigerant from draining back to the compressor when stopped (discharge piping upper loop). For validation tests see section "Manage off cycle migration".

General recommendations are described in the figures below:

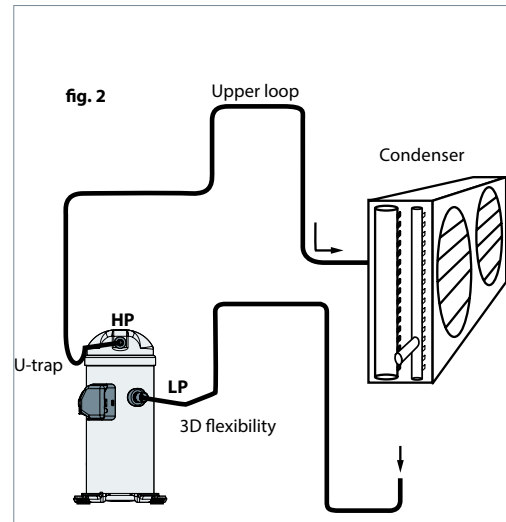
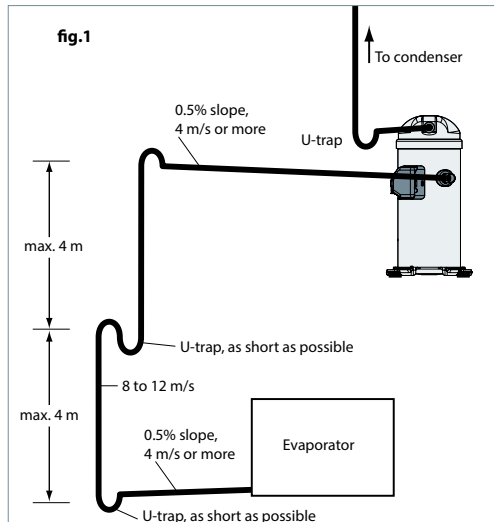

3. Piping should be designed with adequate three-dimensional flexibility to avoid excess vibration. It should not be in contact with the surrounding structure, unless a proper tubing

mount has been installed. For more information on noise and vibration, see section on: "Sound and vibration management".

GENERAL INFORMATION
PRODUCT INFORMATION
SYSTEM DESIGN
INTEGRATION INTO SYSTEM
ORDERING INFORMATION

Design compressor mounting

General requirements

Compressors used in single application must be mounted with flexible grommets

and the manifold assembly must be mounted with flexible grommets onto frame.

Compressors used in parallel application must be mounted with rigid mounting spacers onto rails

During operation, maximum inclination from the vertical plane must not exceed 3 degrees.

Single compressor requirements

LLZ compressors are delivered with flexible grommets, accessory mounting kit.

The grommets must be compressed until contact between the flat washer and the steel mounting sleeve is established. The required bolt size for the LLZ013-034 compressors is M8*45mm. This bolt must be tightened to a torque of 11 Nm.

Mounting grommet

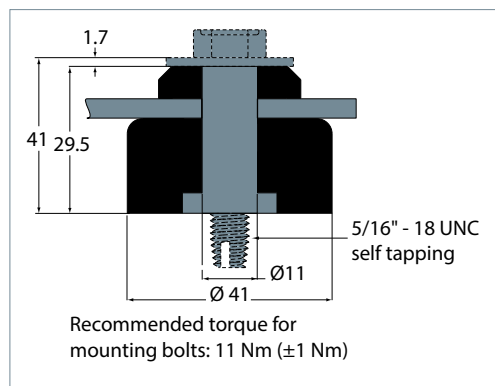

Compressor sound radiation

Typical sounds and vibrations in systems can be broken down into the following three categories:

- Sound radiation (through air)
- Mechanical vibrations (through parts and structure)

- Gas pulsation (through refrigerant)

The following sections focus on the causes and methods of mitigation for each of the above sources.

For sound radiating from the compressors, the emission path is air and the sound waves are travelling directly from the machine in all directions.

Sound levels are as follows:

- For compressors running alone:

Compressor model	50 Hz		60 Hz		Acoustic hood code number
	Sound power dB(A)	Attenuation dBA ①	Sound power dB(A)	Attenuation dBA ①	
LLZ013	78	8	80	8	120Z5052
LLZ015	80	8	83	8	120Z5052
LLZ018	83	10	84	10	120Z5052
LLZ024	85	10	86	10	120Z5053
LLZ034	85	8	86	8	120Z5055

Sound power and attenuation are given at ARI LBP conditions, measured in free space

① Attenuation given with acoustic hood

Materials are UL approved and RoHS compliant

LLZ scroll compressors have a unique discharge valve design that minimizes stopping noise. This results in very low shutdown sound.

Note: During compressor shut down, a short reverse rotation sound is generated. The duration of this sound depends on pressure difference at shut down and should be less than 3 seconds. This phenomenon has no impact on compressor reliability.

Mitigations methods:

We can consider two means to reduce compressors sound radiations:

1. Acoustic hoods are quick and easy to install and do not increase the overall size of the compressors to a great extent. Acoustic hoods are available from Danfoss as accessories. Refer to table above for sound levels, attenuation and code numbers.
2. Use of sound-insulation materials on the inside of unit panels is also an effective means to reduce radiation.

Manage sound and vibration

Mechanical vibrations

Vibration isolation constitutes the primary method for controlling structural vibration. LLZ scroll compressors are designed to produce minimal vibration during operations. The use of rubber isolators on the compressor base plate or on the frame of a manifolded unit is very effective in reducing vibration being transmitted from the compressor(s) to the unit. Rubber grommets are supplied with all LLZ scroll compressors.

Once the supplied rubber grommets have been properly mounted, vibration transmitted from the compressor base plate to the unit are held to a strict minimum. In addition, it is

extremely important that the frame supporting the mounted compressor be of sufficient mass and stiffness to help dampen any residual vibration potentially transmitted to the frame. The tubing should be designed so as to both reduce the transmission of vibrations to other structures and withstand vibration without incurring any damage. Tubing should also be designed for three-dimensional flexibility. For more information on piping design, please see the section entitled "Essential piping design considerations".

Gas pulsation

The LLZ scroll compressors have been designed and tested to ensure that gas pulsation has been minimized for the most commonly encountered refrigeration pressure ratio. On installations where the pressure ratio lies beyond the typical range, testing should be conducted under all expected conditions and operating configurations to ensure that minimum gas pulsation is present.

Mitigations methods:
If an unacceptable level is identified, a discharge muffler with the appropriate resonant volume and mass can be installed.

GENERAL INFORMATION

PRODUCT INFORMATION

SYSTEM DESIGN

INTEGRATION INTO SYSTEM

ORDERING INFORMATION

Requirement

R The operating envelope for LLZ scroll compressors is given in the figures below and guarantees reliable operations of the compressor for steady-state and operation.

Steady-state operation envelope is valid for a suction superheat high than 5K

LLZ compressor operating envelop are difference with refrigerant and with/with out injection. The detail as following.

LLZ Compressor with R404A/R507, code2/4/9, Non Injection

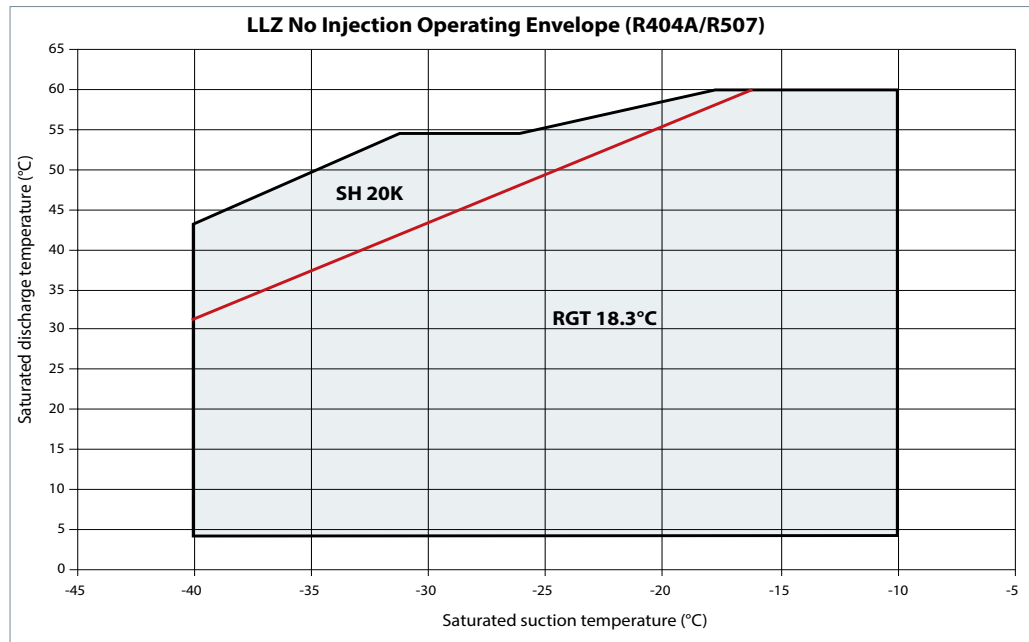

LLZ Compressor with R404A/R507, code2/4/9, with economizer line

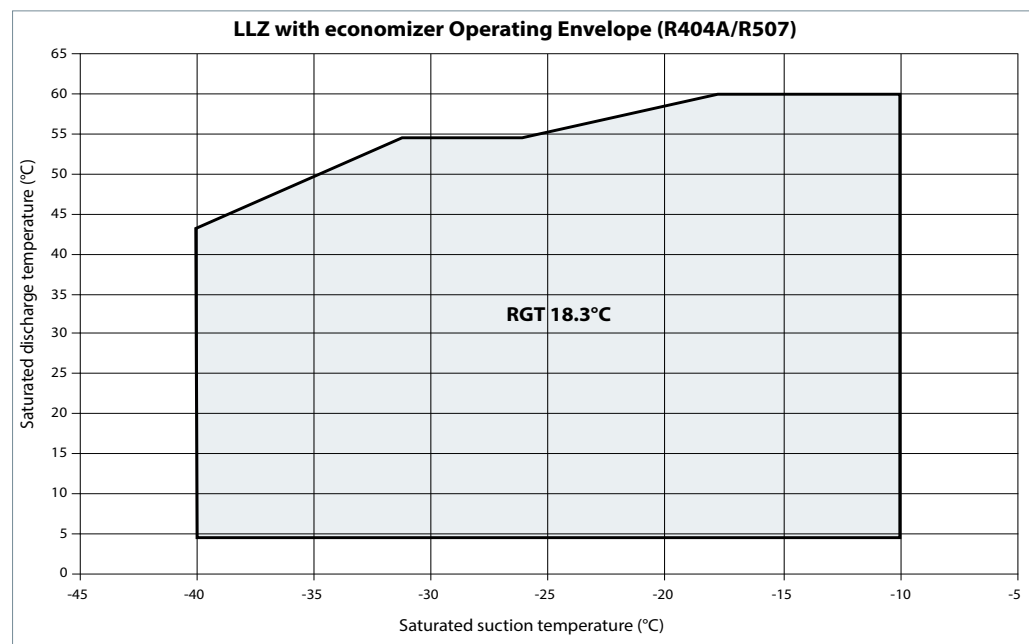

GENERAL INFORMATION
PRODUCT INFORMATION
SYSTEM DESIGN
INTEGRATION INTO SYSTEM
ORDERING INFORMATION

LLZ Compressor with R404A/R507, code2/4/9, with liquid injection(LI)

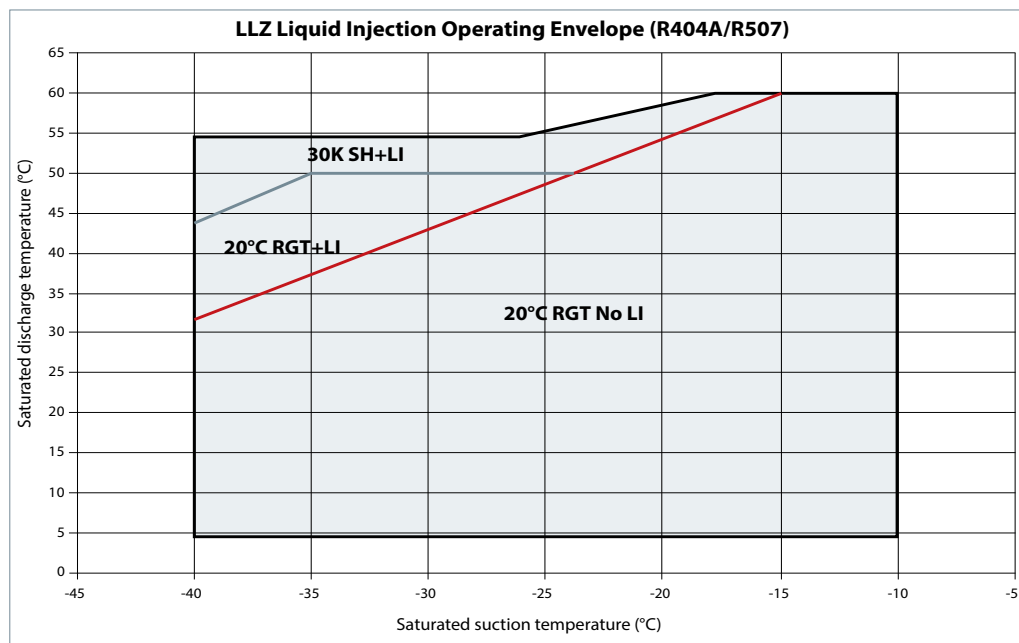

Pressure settings		R404A/R507
Working range high side	bar(g)	5.94-27.74
Working range low side	bar(g)	0.33-3.34
Maximum high pressure safety switch setting	bar(g)	29.7
Minimum low pressure safety switch setting	bar(g)	0.15
Minimum low pressure pump-down switch setting	bar(g)	0.33

R LP and HP safety switches must never be bypassed nor delayed and must stop all the compressors.

When caused low by LP safety switch, limit the number of auto-restart to maximum 5 times within 12 hours.

! HP safety switch must be manual reset

Depending on application operating envelope, you must define HP and LP limits within operating envelope and pressure setting table above.

- The thermostat must be attached to the discharge line within 150 mm from the compressor discharge port and must be thermally insulated and tightly fixed on the pipe.

For LLZ compressors, the external Discharge Gas Temperature protection (DGT) is required if the high and low pressure switch settings do not protect the compressor against operations beyond its specific application envelope.

- The DGT should be set to open at a discharge gas temperature of 135°C.

The discharge gas thermostat accessory kit (code 7750009) includes all components required for installation as shown on the right. DGT installation must respect below requirements:

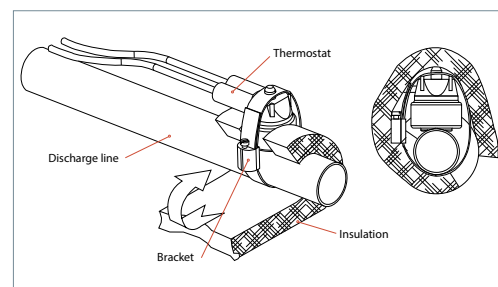

Manage operating envelope

Evaluate the risk

We consider two types of operating envelope management:

<p>Basic:</p> <ul style="list-style-type: none"> • HP and LP switch • MOP (Max Operating Pressure) ensured by expansion device • Condensing pressure control • (DGT integrated) 	<p>Advanced:</p> <ul style="list-style-type: none"> • HP and LP sensor • Operating envelope limits (permanent and transient) integrated into control logic • (DGT integrated)
	<p>No additional test are required</p>

GENERAL INFORMATION
PRODUCT INFORMATION
SYSTEM DESIGN
INTEGRATION INTO SYSTEM
ORDERING INFORMATION

Theory of Injection cycle

Theory of Vapor injection cycle

The below schematic shows a system configuration with a heat exchanger acting as an economizer for economized cycle (12345671).

The economizer is used to provide subcooling to the refrigerant leaving the condenser before it enters into the evaporator. This subcooling process provides an increased capacity gain for

the system. Meanwhile, another small amount of refrigerant leaving the condenser goes through the expansion device and is then evaporated and superheated. The superheated refrigerant is then injected into the mid-compression cycle of the compressor and compressed together with the suction flow. The injected vapour also provides cooling and therefore lowers the discharge temperature.

Economizer system configuration

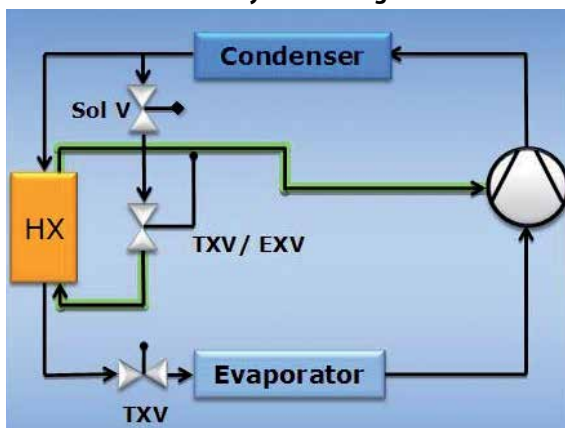

Economizer cycle 12345671

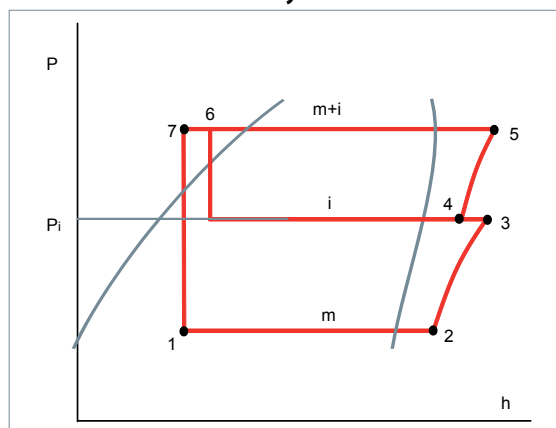

Theory of liquid injection cycle

The below schematic shows a system configuration with a liquid injection cycle (1234561). The liquid refrigerant is injected into scroll pocket, the injected liquid will flash and absorb heat from compressed gas and scroll set then cooling the discharge gas, keep discharge gas temperature within safe limits.

Liquid injection is achieved by utilization of a Discharge Temperature Responsive Expansion Valve. The same valve can be used for all LLZ models with R404A. The valve can regulate the injection mass flow according to discharge temperature.

An additional solenoid valve has to be installed in case of power shortage to prevent from liquid injection.

For the liquid injection system to be effective, a minimum of 5°K sub cooled liquid at the at the injection valve inlet is required. To prevent a partial or full blockage at the injection port caused through shavings, foreign bodies etc a filter should be installed in the liquid line prior to the injection valve inlet.

Liquid injection system configuration

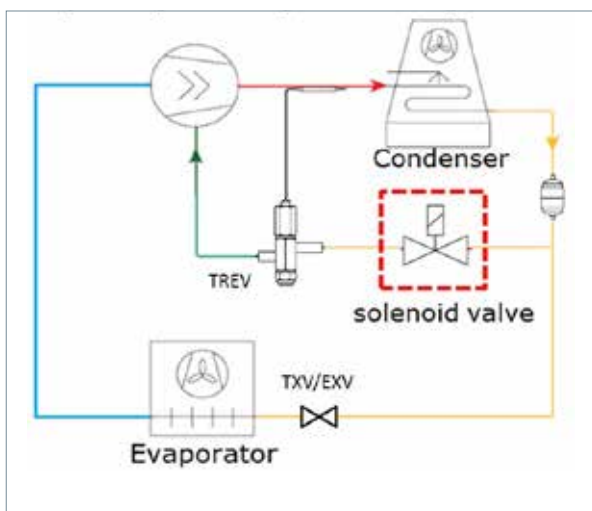

Liquid injection cycle 1234561

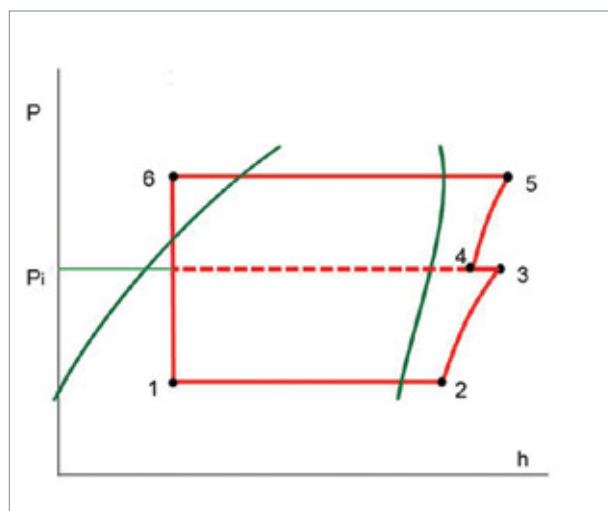

TREV installation

- o Recommended TREV : Sporlan Y1037-1/2-230-3/8ODFX3/8ODF
- o Liquid injection special accessories:
 - Thermal insulator 1pc
 - Rotolock sleeve 1" to 3/8" injection connection 1pc
 - Gasket o-ring 1pc

Any of the commonly used types of solders or brazing materials, e.g., 95-5, Sil-Fos, Easy-Flo, Phos-Copper, Stay Brite 8 or equivalents may be used for copper to copper connections. It is important, however, regardless of the solder used, to direct the flame away from the valve body. As an extra precaution, a wet cloth may be wrapped around the body during the soldering operation. Screw the nut with compressor injection fitting (Figure A/figureB) ; Valve position should be 30° to 45° with compressor center axis, the nut screw torque is 80±10NM.

o Sleeve solder and valve location
 Insert nut first, solder sleeve with valve outlet pipe (Figure A) ; It is not necessary to disassemble the TREV when soldering to the connecting lines.

Figure A Rotolock fitting

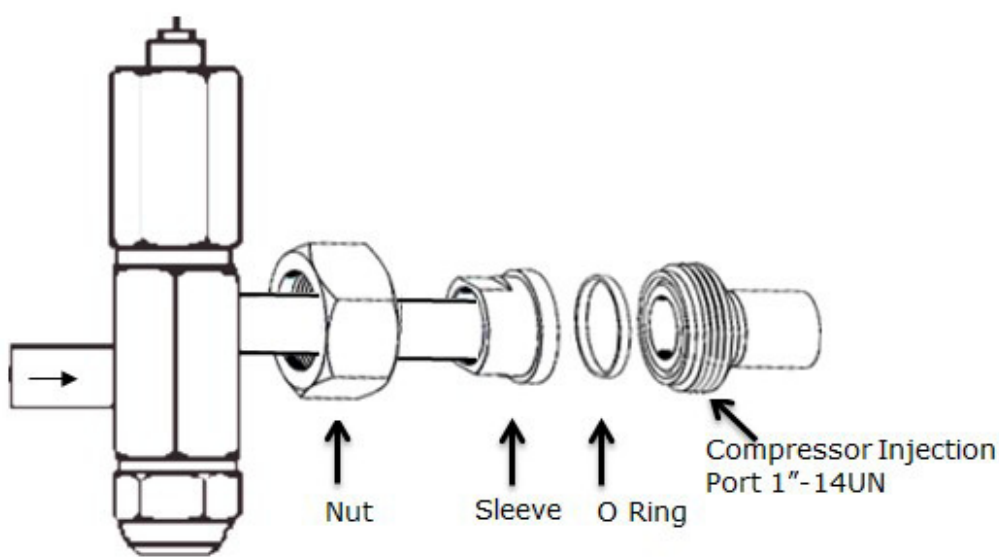
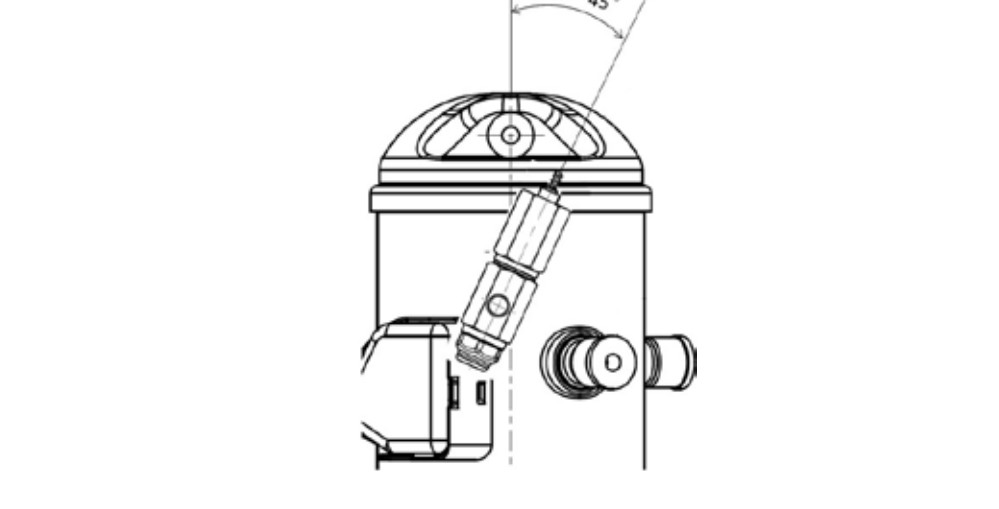

Figure B Valve location



GENERAL INFORMATION
PRODUCT INFORMATION
SYSTEM DESIGN
INTEGRATION INTO SYSTEM
ORDERING INFORMATION

Theory of Injection cycle

o Bulb location (Figure C)

- Good thermal contact between the bulb and discharge line is essential. Before assembly, make sure the pipe and bulb surface is clean, remove oil and impurities. We recommend to add thermal Conductive Adhesive or silver paint at the contact surface .
- Strapping the sensing bulb as close to the compressor discharge valve as possible, not to

exceed 20cm. Strap the center of the bulb with discharge pipe, the screw force should be taken care, otherwise the bulb will be deformed, the setting will be changed.

- The control temperature of the valve may be slightly higher due to the cooling effects of ambient temperature on the sensing bulb. Therefore, insulating the bulb with insulator is mandatory. Remove the paper surface, align the cut with clamp, wrap around bulb.

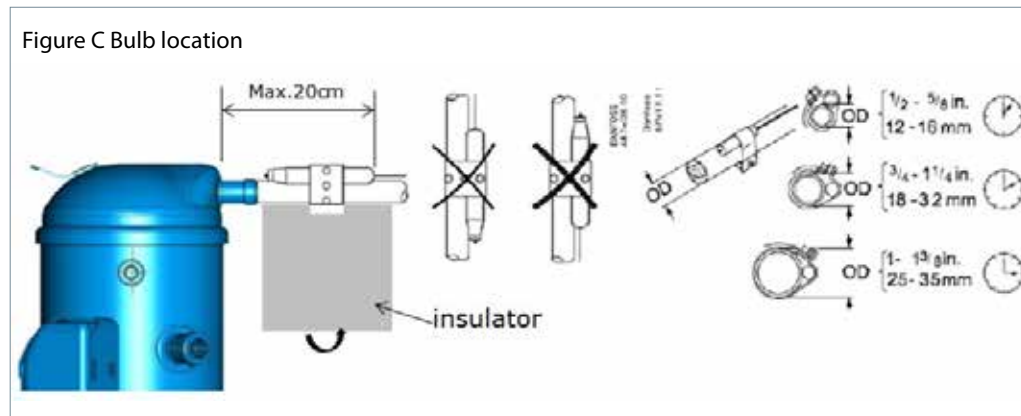

* Others refer to Sporlan SD-168 "Installation & field service instructions" delivered with valve.

Manage superheat

During normal operation, refrigerant enters the compressor as a superheated vapor. Liquid flood back occurs when a part of the refrigerant entering the compressor is still in liquid state.

Liquid flood back can cause oil dilution and, in extreme situations lead to liquid slugging that can damage compression parts.

Requirement

In steady state conditions,

- suction superheat must be higher than 5K
- Discharge superheat must be higher than 15K
- Oil superheat must be higher than 10K

In transient conditions,

- Discharge superheat must be higher than 5K
- Oil superheat must be higher than 10K

Discharge temperature sensor must be placed onto the discharge fitting and be insulated.

Oil temperature sensor must be placed between oil sight glass and compressor baseplate and be insulated.

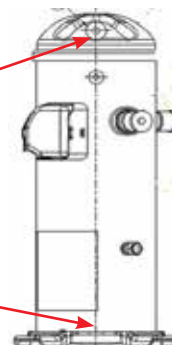

Evaluate the risk

Use the tables below in relation with the system charge and the application to quickly evaluate the risk and potential tests to perform.

	BELOW charge limit	ABOVE charge limit
	No test or additional safeties required	Liquid flood back test

Charge limit is defined in table below:

	Models	Refrigerant charge limit (kg)
Single	LLZ013-015-018	4.54
	LLZ024-034	7.26

Test, criteria and solutions

Test	Purpose	Test condition	Pass criteria	Solutions
Liquid flood back test	Steady-state	<p>Liquid flood back testing must be carried out under expansion valve threshold operating conditions: a high pressure ratio and minimum evaporator load (A).</p>	<p>Oil superheat > 10K Steady-state discharge superheat > 15K</p>	<p>1. Check expansion valve selection and setting 2. Add a suction accumulator*</p>
	Transient	<p>Tests must be carried out with most unfavorable conditions :</p> <ul style="list-style-type: none"> • fan staging, • compressor staging • ... 	<p>Oil superheat > 10K Transient discharge superheat > 5K</p>	<p>1. Check expansion valve selection and setting. -For Thermostatic expansion valve (TXV) check bulb position... -For Electronic expansion valve (EXV) check measurement chain and PID.... 2. Add a suction accumulator*</p>
Defrost test	Check liquid floodback during defrost cycle	Defrost test must be carried out in the most unfavorable condition (at 0°C evaporating temperature)	<p>Oil superheat > 10K Transient discharge superheat > 5K</p>	In refrigeration system, there are different defrost method, such as electric method. (for more details see "Control Logic").

*Suction accumulator offers protection by trapping the liquid refrigerant upstream from the compressor. The accumulator should be sized at least 50 % of the total system charge. Suction accumulator dimensions can impact oil return (gas velocity, oil return hole size...), therefore oil return has to be checked according to section "Manage oil in the circuit".

Manage off cycle migration

- R** Off-cycle refrigerant migration happens:
- when the compressor is located at the coldest part of the installation, refrigerant vapor condenses in the compressor.
 - or directly in liquid-phase by gravity.

When the compressor starts running again, the refrigerant diluted in the oil generates poor lubrication conditions. In extreme situations, this leads to liquid slugging that can damage compression parts.

Requirement

Amount of liquid refrigerant in the compressors must not overpass the charge limit (refer to charge limit table in section "Manage superheat")

Evaluate the risk

Use the table below in relation with the system charge (refer to charge limit table in section "Manage superheat") and the application to

quickly define necessary safeties to implement and test to perform:

	BELOW CHARGE LIMIT	ABOVE CHARGE LIMIT
Non split	No test or additional safeties required	<ul style="list-style-type: none"> • Belt type crank case heater * • Migration test • (External Non-Return Valve)
Split	Since each installation is unique, no test can fully evaluate off-cycle migration, therefore the following safeties are required: <ul style="list-style-type: none"> • Belt type crankcase heater * • Liquid Line Solenoid Valve***+ pump-down cycle*** 	

Test, criteria and solutions

Test N°	Purpose	Test condition	Pass criteria	Solutions
Migration test	Check that there is no migration of refrigerant into the compressor (either liquid or vapour condensating)	Energize CCH*. Stabilize the non-running system at a pressure equivalent to 5°C. Raise the system pressure equivalent to 20°C. When saturated condensing temperature reaches 20°C then start the unit.	When all compressors are idle: <ul style="list-style-type: none"> • Check in liquid line sight glass that there is no liquid refrigerant transfer • Oil superheat must be >10K during off-cycle After compressors has started: <ul style="list-style-type: none"> • Oil superheat must remain >10K 	1. Check bulb position, tightness of expansion device, 2. add LLSV** 3. add pump down cycle*** 4. Check Crank case heater efficiency

Oil temperature sensor must be placed between oil sight glass and compressor baseplate and be insulated.

It is recommended that the heater be turned on for a minimum of 12 hours prior to starting the compressor.

*Crank case heater (CCH)

The belt type sump heaters are designed to protect the compressor against off-cycle migration of refrigerant. Additional heater power or thermal insulation might be needed in case of ambient temperature below -5°C and a wind speed above 5m/second. The heater must be energized whenever all the compressors are off.

Crank case heater accessories are available from Danfoss (see section "Accessories").

**Liquid line solenoid valve (LLSV)

A LLSV is used to isolate the liquid charge on the condenser side, thereby preventing against charge transfer to the compressor during off-cycles. The quantity of refrigerant on the low-pressure side of the system can be further reduced by using a pump-down cycle in association with the LLSV.

***Pump-down cycle

By decreasing pressure in the sump, pump down:

- evacuates refrigerant from oil
- set the sump saturating pressure much lower than ambience temperature and due to that, avoid refrigerant condensation in the compressor.

Pump-down must be set higher than 0.33Bar(g) for R404a.

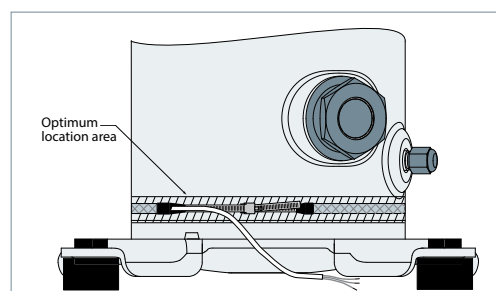

For more details on pump-down cycle see section "Control Logic".

Control logic

Safety control logic requirements

	Tripping conditions		Re-start conditions	
	Value	Time	Value	Time
HP switch	See Pressure settings table from section "Manage operating envelope"	Immediate, no delay. No by-pass	Conditions back to normal. Switch closed again	Manual reset
LP safety switch				Maximum 5 auto reset during a period of 12 hours, then manual reset.
Electronic module (Motor protection, DGT)				Contact M1-M2 opened

Cycle rate limit requirements

Danfoss requires a minimum compressor running time of 2 minutes to ensure proper oil return and sufficient motor cooling. Additionally, compressor service life is based on a maximum of 12 starts per hour.

Therefore, to guarantee these 2 requirements, a three-minute (180- sec) time out is recommended.

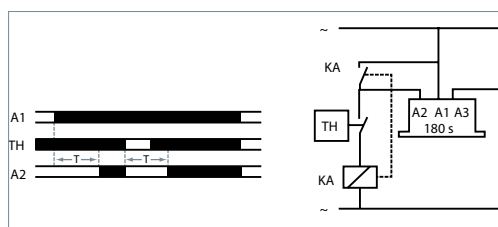

Oil management logic recommendations

In some cases, oil management can be enhanced by control logic:

- If oil return test failed, a function can be integrated in control to run all compressors simultaneously during one minute every hour in order to boost oil return. Time and delay can be fine-tuned by oil return test N°1 in section "Manage oil in the circuit". During oil boost, pay special attention to superheat management to avoid liquid flood back and foaming.

- If after running long time in full load, oil unbalance appears, then a function can be in control to stop all compressors in manifold during one minute every two hours in order to balance oil between compressors. Time and delay can be fine-tuned by Oil balancing test N°2 in section "Manage oil in the circuit".

Defrost logic recommendations

In refrigeration system applications, there are different defrost methods, such as electric heating defrost, hot gas bypass defrost, reversible defrost etc. For the systems which use hot gas bypass or reversible defrost method, suction accumulator is necessary as a result of the possibility of a substantial quantity of liquid refrigerant remaining in the evaporator.

This liquid refrigerant can then return to the compressor, either flooding the sump or as a dynamic liquid slug when the cycle switch back to normal cooling operations. Sustained and repeated liquid slugging and flooding can seriously impair the oil's ability to lubricate the compressor bearings. In such cases a suction accumulator is a must.

Pump-down logic recommendations

Pump-down cycle: Once the system has reached its set point and is about to shut off, the LLSV on the liquid line closes. The compressor then pumps the majority of the refrigerant charge into the high pressure side before the system stops on the low pressure pump-down switch. This step reduces the amount of charge on the low side in order to prevent off-cycle migration.

A pump-down cycle represents one of the most effective ways to protect against the off-cycle migration of refrigerant; however it is only convenient to apply on application with thermostatic control.

Rack application with pressostatic control can use timer delay to empty the evaporators before the stop. Time should be carefully set to not interfere with the low safety pressure switch.

For low pressure pump-down switch settings, refer to section "High and low pressure protection". For suggested wiring diagrams, please see section "Wiring diagram".

Under certain conditions, the internal valve may not completely seal, and due to the refrigerant back flow the compressor might restart during pump-down applications. Repeated short cycling can result in a compressor breakdown. It is recommended to install an external magnetic

check valve (such as Danfoss Part No. 120Z5046) close to the compressor's discharge connector so the discharge volume is minimized.

A magnetic check valve is recommended for this as it offers the best solution regarding minimal required and maximal pressure drop over the wide application envelope of the LLZ scroll compressors. If a Danfoss NRV check valve is applied it has to be carefully selected for the specific operation conditions of the individual system.

Tests for pump down cycle approval:

- As the pump-down switch setting is inside the application envelope, tests should be carried out to check unexpected cut-out during transient conditions (i.e. defrost - cold starting). When unwanted cut-outs occur, the low pressure pump-down switch can be delayed. In this case a low pressure safety switch without any delay timer is mandatory.
- While the thermostat is off, the number of pressure switch resets should be limited to avoid short cycling of the compressor. Use dedicated wiring and an additional relay which allows for one shot pump-down.

Provide power supply and electrical protection

Wiring information

Requirements:

- An additional external overload protection is still advisable for either alarm or manual reset. For overload setting, take the max current you can face on the application and add 10%. Setting must always be lower than Max Operating Current (see table...)
- HP safety switch and DGT must be wired in the safety chain. Other safety devices such as LP can be either hardware or software managed.

- Provide separate electrical supply for the heaters so that they remain energized even when the machine is out of service (e.g. seasonal shutdown).

The wiring diagrams below are examples for a safe and reliable compressor wiring:

The wiring diagrams below are examples for a safe and reliable compressor wiring:

Compressor model LLZ 013 - 015 - 018 - 024 - 034

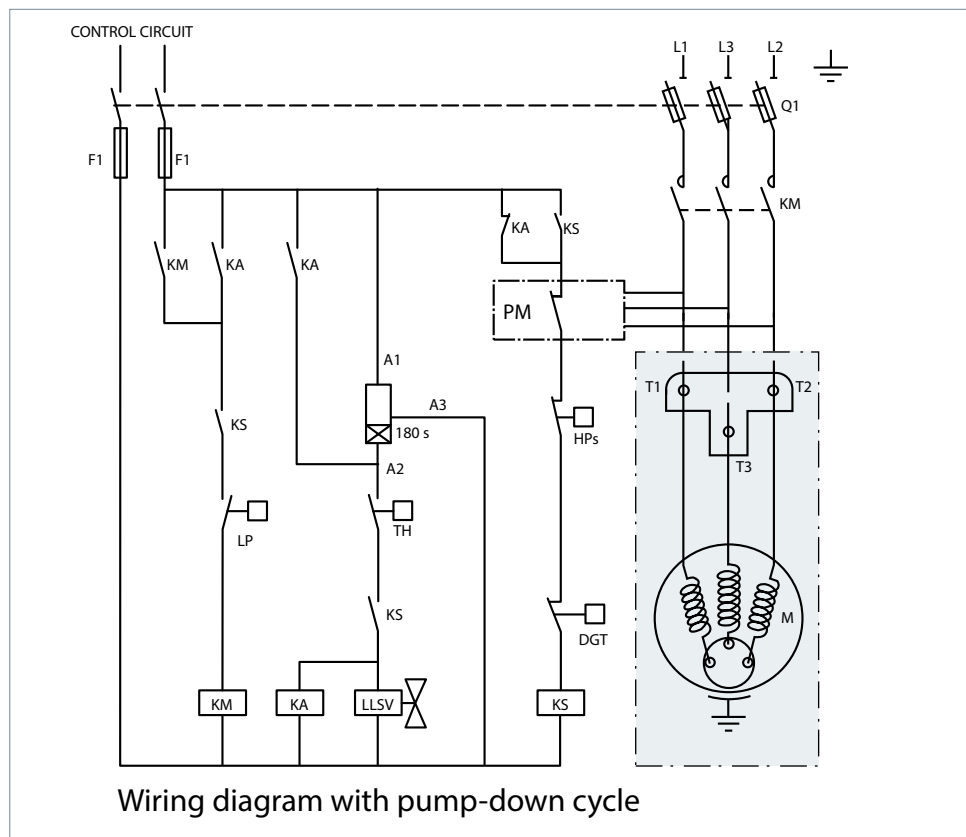

Control device.....	TH
Optional short cycle timer (3 mins) .180 s	
Control relay.....	KA
Liquid Line Solenoid valve.....	LLSV
Compressor contactor.....	KM
Phase monitor.....	PM
Safety lock out relay.....	KS
Pump-down control low pressure switch.....	LP
High pressure safety switch.....	HPs
Fused disconnect.....	Q1
Fuses.....	F1
Compressor motor.....	M
Discharge gas thermostat.....	DGT

Note:

For LLZ phase monitors are mandatory. The selected phase monitor should lock out the compressor from operation in reverse.

Reduce moisture in the system

Excessive air and moisture

- can increase condensing pressure and cause excessively high discharge temperatures.
- can create acid giving rise to copper plating.
- can destroy the lubricating properties of the oil.

All these phenomena can reduce service life and cause mechanical and electrical compressor failure.

Requirements

LLZ compressors are delivered with < 100 ppm moisture level.

At the time of commissioning, system moisture content may be up to 100 ppm. During operation, the filter drier must reduce this to a level between 20 and 50 ppm.

Solutions

To achieve this requirement, a properly sized and type of drier is required. Important selection criteria's include:

- driers water content capacity,
- system refrigeration capacity,
- system refrigerant charge.

For new installations with LLZ compressors with polyolester oil, Danfoss recommends using the Danfoss DML (100% molecular sieve) solid core filter drier.

GENERAL INFORMATION

PRODUCT INFORMATION

SYSTEM DESIGN

INTEGRATION INTO SYSTEM

ORDERING INFORMATION

Assembly line procedure

Compressor storage

Store the compressor not exposed to rain, corrosive or flammable atmosphere between -35°C and 70°C when charged with nitrogen.

Compressor holding charge

Each compressor is shipped with a nominal dry nitrogen holding charge between 0.4 and 0.7 bar and is sealed with elastomer plugs.

-  Respect the following sequence:
 - Remove the nitrogen holding charge via the suction schrader valve to avoid an oil mist blow out.

- Remove the suction plug first and the discharge plug afterwards to avoid discharge check valve gets stuck in open position.

An opened compressor must not be exposed to air for more than 20 minutes to avoid moisture is captured by the PVE oil.

Handling

Compressor handling

LLZ Compressors are provided with a lifting lug. This lug should always be used to lift the compressor.

Once the compressor is installed, the lifting lug should never be used to lift the complete

installation. The compressor must be handled with caution in the vertical position, with a maximum inclination of 15° from vertical.

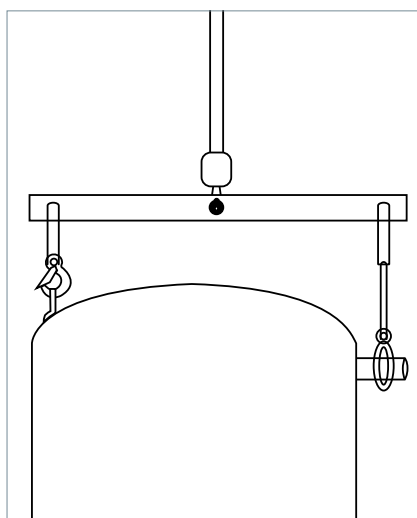

Piping assembly

Good practices for piping assembly is a pre-requisite to ensure compressor service life.

System cleanliness

Circuit contamination possible cause:	Requirement:
Brazing and welding oxides	During brazing, flow nitrogen through the system
Filings and particles from the removal of burrs in pipe-work	Remove any particles and burrs generated by tube cutting and hole drilling
Moisture and air	Use only clean and dehydrated refrigeration grade copper tubing Opened compressor must not be exposed to air more than 20 minutes to avoid moisture captured by POE oil

Brazing procedure:

- Brazing operations must be performed by qualified personnel.
- Make sure that no electrical wiring is connected to the compressor.
- To prevent compressor shell and electrical box overheating, use a heat shield and/or a heat-absorbent compound.
- Clean up connections with degreasing agent
- Flow nitrogen through the compressor.
- Use flux in paste or flux coated brazing rod.

- Use brazing rod with a minimum of 5% silver content.
- It is recommended to use double-tipped torch using acetylene to ensure a uniform heating of connection.
- For discharge connections brazing time should be less than 2 minutes to avoid NRVI damages if any.
- To enhance the resistance to rust, a varnish on the connection is recommended.

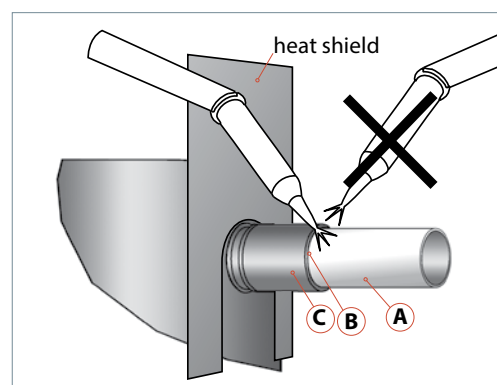

R Before eventual un-brazing of the compressor or any system component, the refrigerant charge must be removed.

System pressure test and leak detection

! The compressor has been strength tested and leak proof tested (<3g/year) at the factory. For system tests:

- Always use an inert gas such as Nitrogen or Helium.

- Pressurize the system on HP side first then LP side.
- Do not exceed the following pressures:

Maximum compressor test pressures	
Maximum compressor test pressure high side (HP)	31.1 bar (g)
Maximum compressor test pressure low side (LP)	31.1 bar (g)

Assembly line procedure

GENERAL INFORMATION

Vacuum evacuation and moisture removal

Requirements:

- Never use the compressor to evacuate the system.
- Connect a vacuum pump to both the LP and HP sides.
- Evacuate the system to a pressure of 500 $\mu\text{m Hg}$ (0.67 mbar) absolute.

Recommendations:

- Energized heaters improve moisture removal.
- Alternate vacuum phases and break vacuum with Nitrogen to improve moisture removal.

For more detailed information see "Vacuum pump-down and dehydration procedure" TI-026-0302.

PRODUCT INFORMATION

Refrigerant charging



Initial charge:

- For the initial charge, the compressor must not run.
- Charge refrigerant as close as possible to the nominal system charge.
- This initial charging operation must be done in liquid phase between the condenser outlet and the filter drier.

If needed, a complement of charge can be done:

- In liquid phase while compressor is running by slowly throttling liquid in.
- On the low pressure side, as far away as possible from the compressor suction connection.
- Never bypass safety low pressure switch.

For more detailed information see "Recommended refrigerant system charging practice" FRCC.EN.050.

SYSTEM DESIGN

Dielectric strength and insulation resistance tests

The tests are performed on each compressor at the factory between each phase and ground.

- Dielectric strength test is done with a high potential voltage (hi-pot) of $2U_n + 1000\text{V AC}$ at least, and leakage current must be less than 5 mA. Additional tests of this type are not recommended as it may reduce motor lifetime. Nevertheless, if such a test is necessary, it must be performed at a lower voltage.

- Insulation resistance is measured with a 500 V DC megohm tester and must be higher than 1 megohm.

- The presence of refrigerant around the motor windings will result in lower resistance values to ground and higher leakage current readings. Such readings do not indicate a faulty compressor. To prevent this, the system can be first operated briefly to distribute refrigerant.



Do not use a megohm meter nor apply power to the compressor while it is under vacuum as this may cause internal damage.

INTEGRATION INTO SYSTEM

ORDERING INFORMATION

Commissioning

Preliminary check



Check electrical power supply:

- Phase order: For LLZ compressors equipped with an electronic module, reverse rotation will be automatically detected. For more details refer to section "Motor protection".

- Voltage and voltage unbalance within tolerance: For more details refer to section "Motor voltage".

Initial start-up

- Surface sump heaters must be energized at least 6 hours in advance to remove refrigerant.
- A quicker start-up is possible by "jogging" the compressor to evacuate refrigerant. Start the

compressor for 1 second, then wait for 1 to 2 minutes. After 3 or 4 jogs the compressor can be started. This operation must be repeated for each compressor individually.

System monitoring

The system must be monitored after initial startup for a minimum of 60 minutes to ensure proper operating characteristics such as:

- Correct superheat and subcooling.
- Current draw of individual compressors within acceptable values (max operating current).
- No abnormal vibrations and noise.
- Correct oil level.

If Oil Top-up is needed, it must be done while the compressor is idle. Use the schrader connector or any other accessible connector on the compressor suction line. Always use original Danfoss POE oil 160SZ from new cans. For more detailed information see "Lubricants filling in instructions for Danfoss Commercial Compressors" TI 2-025-0402.

Dismantle and disposal

GENERAL INFORMATION
PRODUCT INFORMATION
SYSTEM DESIGN
INTEGRATION INTO SYSTEM
ORDERING INFORMATION



Danfoss recommends that compressors and compressor oil should be recycled by a suitable company at its site.

Packaging

Single pack

Compressors are packed individually in a cardboard box. They can be ordered in any quantity. Minimum ordering quantity = 1.

As far as possible, Danfoss will ship the boxes on full pallets of 9 compressors according below table.

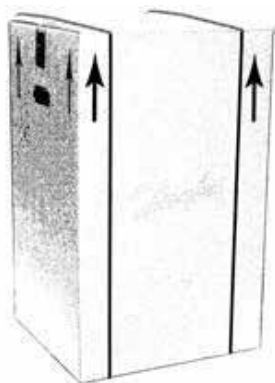

Compressor model	Length (mm)	Width (mm)	Height (mm)	Gross weight (kg)
LLZ013	1169	965	730	460
LLZ015	1169	965	718	460
LLZ018	1169	965	718	468
LLZ024	1169	965	775	495
LLZ034	1169	965	817	544

Note : Here including 9 single pack compressors

Industrial pack

Compressors are not packed individually but are shipped all together on one pallet. They can be ordered in quantities of full pallets only,

multiples of 12 compressors, according below table.

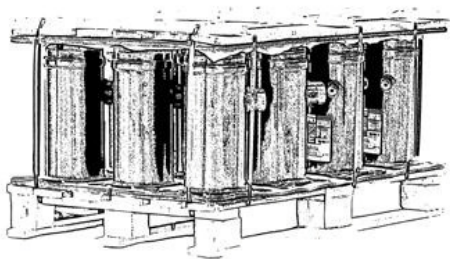

Compressor model	Nbr*	Length (mm)	Width (mm)	Height (mm)	Gross weight (kg)	Static stacking pallets
LLZ013	12	1170	815	665	538	4
LLZ015	12	1170	815	750	538	4
LLZ018	12	1170	815	750	550	4
LLZ024	12	1170	815	720	586	4
LLZ034	12	1170	815	817	651	4

Ordering codes

Compressor code numbers Danfoss scroll compressors LLZ can be ordered in either industrial packs or in single packs. Please use the code numbers from below tables for ordering.

Single pack

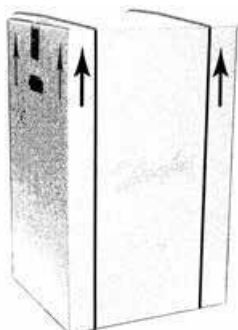

Compressor model	Model Variation	Connections	Feature	Code no.		
				2	4	9
				200-230/3/50 208-230/3/60	380-415/3/50 460/3/60	380-400/3/60
LLZ013	T	Q	9	121L9519	121L9517	121L9531
LLZ015	T	Q	9	121L9515	121L9513	121L9529
LLZ018	T	Q	9	121L9511	121L9509	121L9527
LLZ024	T	Q	9	121L9507	121L9505	121L9525
LLZ034	T	Q	9	121L9523*	121L9521	121L9533*

Note: These codes are preliminary

Industrial pack

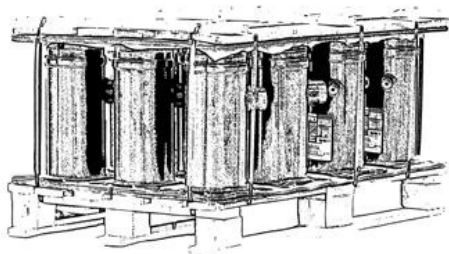

Compressor model	Model Variation	Connections	Feature	Code no.		
				2	4	9
				200-230/3/50 208-230/3/60	380-415/3/50 460/3/60	380-400/3/60
LLZ013	T	Q	9	121L9518	121L9516	121L9530
LLZ015	T	Q	9	121L9514	121L9512	121L9528
LLZ018	T	Q	9	121L9510	121L9508	121L9526
LLZ024	T	Q	9	121L9506	121L9504	121L9524
LLZ034	T	Q	9	121L9522*	121L9520	121L9532*

Note: These codes are preliminary

Accessories

Crankcase heater



Type	Code No	Description	Application	Packaging	Pack Size
	120Z5040	Belt type crankcase heater, 70 W, 240 V, UL, CE mark	All models	Multipack	4
	120Z5041	Belt type crankcase heater, 70 W, 400/460 V, UL, CE mark		Multipack	4
	120Z5042	Belt type crankcase heater, 70 W, 575 V, UL, CE mark		Multipack	4
	120Z0059	Belt type crankcase heater, 65 W, 230 V, UL, CE mark		Multipack	6
	120Z0060	Belt type crankcase heater, 65 W, 400 V, UL, CE mark		Multipack	6

Discharge temperature protection



Type	Code No	Description	Application	Packaging	Pack Size
	7750009	Discharge thermostat kit	All models	Multipack	10
	7973008	Discharge thermostat kit	All models	Industry pack	50

Magnetic discharge non return valve



Type	Code No	Description	Application	Packaging	Pack Size
	120Z5046	Magnetic discharge non return valve	All models	Multipack	6

Lubricant



Type	Code No	Description	Application	Packaging	Pack Size
	120Z5035	PVE lubricant, (0.95 litre can)	All models	Multipack	1

Accessories

Mounting kit



Type	Code No	Description	Application	Packaging	Pack Size
	120Z0629	Mounting kit for 1 scroll compressor including 4 grommets, 4 sleeves, 4 bolts, 4 washers, rotolock connection kit for suction, discharge, economizer fitting and Liquid injection fitting for 1 scroll compressor including 3 Teflon seals, 2 nuts, 3 sleeves, 1 thermal insulator.	LLZ013/015/018	single	1
	120Z0630	Mounting kit for 1 scroll compressor including 4 grommets, 4 sleeves, 4 bolts, 4 washers, rotolock connection kit for suction, discharge, economizer fitting and Liquid injection fitting for 1 scroll compressor including 3 Teflon seals, 2 nuts, 3 sleeves, 1 thermal insulator.	LLZ024/034	single	1

Mounting hardware



Type	Code No	Description	Application	Packaging	Pack Size
	120Z5017	Mounting grommet	All models	Single Pack	1
	120Z5014	Mounting sleeve	All models	Single Pack	1
	120Z5031	Mounting kit, including 1 bolt, 1 sleeve, 1 washer	All models	Single Pack	1
	120Z5064	Mounting kit for 1 scroll compressor including 4 grommets, 4 sleeves, 4 bolts, 4 washers	All models	Single Pack	1

Acoustic hood



Type	Code No	Description	Application	Packaging	Pack Size
	120Z5052	Acoustic hood for scroll compressor	LLZ013-015-018	Single pack	1
	120Z5053	Acoustic hood for scroll compressor	LLZ024	Single pack	1
	120Z5055	Acoustic hood for scroll compressor	LLZ034	Single pack	1

Accessories

Terminal box



Type	Code No	Description	Application	Packaging	Pack Size
	120Z5018	Square terminal box (C & Q version)	C and Q version	Multipack	10

IP54 upgrade kit



Type	Code No	Description	Application	Packaging	Pack Size
	118U0057	IP54 upgrade kit	All models	Multipack	6

GENERAL INFORMATION

PRODUCT INFORMATION

SYSTEM DESIGN

INTEGRATION INTO SYSTEM

ORDERING INFORMATION

Danfoss Commercial Compressors

is a worldwide manufacturer of compressors and condensing units for refrigeration and HVAC applications. With a wide range of high quality and innovative products we help your company to find the best possible energy efficient solution that respects the environment and reduces total life cycle costs.

We have 40 years of experience within the development of hermetic compressors which has brought us amongst the global leaders in our business, and positioned us as distinct variable speed technology specialists. Today we operate from engineering and manufacturing facilities spanning across three continents.



Danfoss Scrolls



Danfoss Inverter Scrolls



Danfoss Turbocor Compressors



Danfoss Light Commercial Refrigeration Compressors



Danfoss Maneurop Reciprocating Compressors



Danfoss Optyma Condensing Units

Our products can be found in a variety of applications such as rooftops, chillers, residential air conditioners, heatpumps, coldrooms, supermarkets, milk tank cooling and industrial cooling processes.

<http://cc.danfoss.com>

Danfoss Commercial Compressors, BP 331, 01603 Trévoux Cedex, France | +334 74 00 28 29



Danfoss can accept no responsibility for possible errors in catalogues, brochures and other printed material. Danfoss reserves the right to alter its products without notice. This also applies to products already on order provided that such alterations can be made without subsequential changes being necessary in specifications already agreed. All trademarks in this material are property of the respective companies. Danfoss and the Danfoss logotype are trademarks of Danfoss A/S. All rights reserved.